

TWIN/FULL/QUEEN ASSEMBLY INSTRUCTIONS

Figure 1

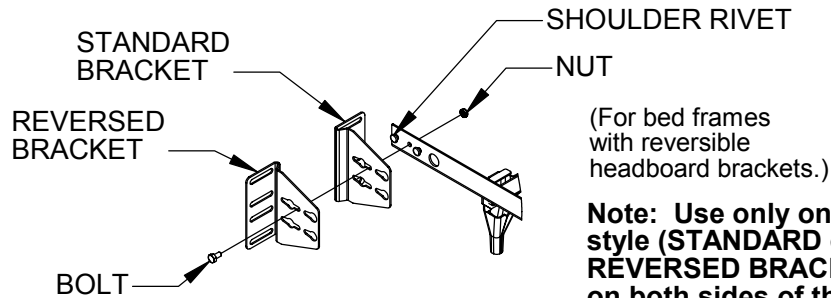

Note: Use only one style (STANDARD or REVERSED BRACKET) on both sides of the bed.

Step 1 For bed frames with reversible headboard brackets only: Mount HEADBOARD BRACKETS to SHOULDER RIVETS at end of side rails. Secure tightly with NUT and short BOLT. Bracket may be reversed to accommodate wide headboards. See Figure 1.

Step 2 Slide END CAPS onto side rails. Swing out CROSS ARMS to 90 degrees. See Figure 2.

WARNING: END CAPS MUST BE PLACED OVER END OF SIDE RAILS TO AVOID SERIOUS INJURY.

Figure 2

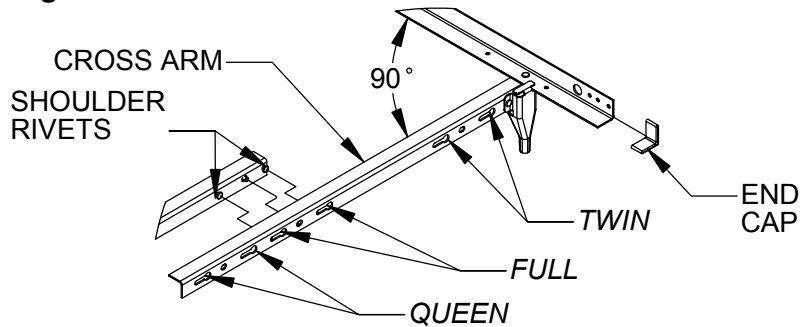

Step 3 Determine the desired bed size (Twin, Full, or Queen). Overlap CROSS ARMS and engage SHOULDER RIVETS into proper keyholes. **Note: Both rivet heads must engage in keyhole slots.** See Figure 2.

Step 4 If optional CROSS SUPPORT is provided, attach with NUTS and BOLTS as shown in Figure 3.

Step 5 Install foot attachments as shown in Figure 4. It may be necessary to tap PLASTIC SOCKETS into place. Locking rollers, if provided, should be installed at the foot of the bed.

Figure 3

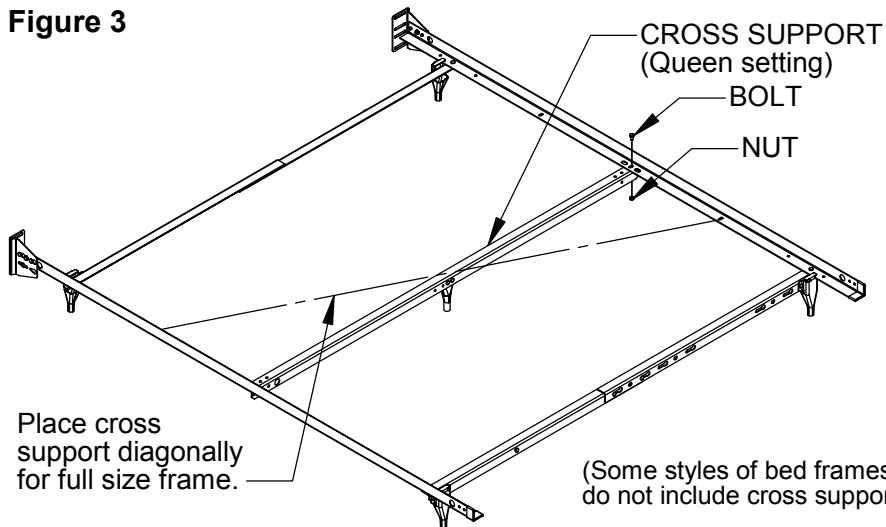
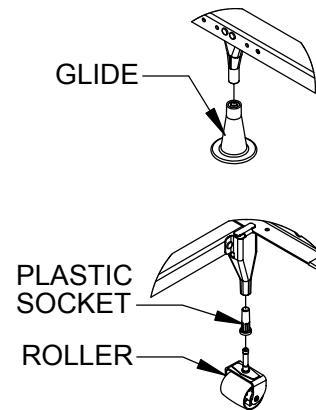
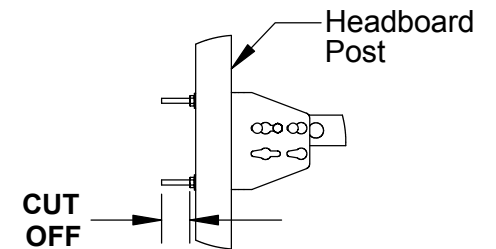

Figure 4



WARNING: When attaching this frame to a headboard with narrow posts, it is recommended that any excess bolt be cut off after attachment. See figure below.



DATE 09-26-03	DWG. NO. 99300574
DO NOT SCALE DRAWING SHEET 1 OF 2	